

Technische Daten:

Fläche Bühnenboden: 5,94 x 4,56m

Fläche Dach: 5,94 x 5,04m

Höhe Bühnenboden 0,95 – 1,25m

Lichte Höhe vorne: 3,53m

Gesamthöhe: 4,7m

Dachstruktur: PVC Blache über Aluminiumtraversen

Bodenbelag: Siebdruckplatte, rutschfest, wasserabweisend

Tragfähigkeit Dach: 2220kg, verteilt

90° schwenkbare Deichsel, Kugelkopfkupplung

Transportmass: 7,6 x 2,4 x 3,7m

Eigengewicht: 2450kg, Gesamtgewicht 2600kg

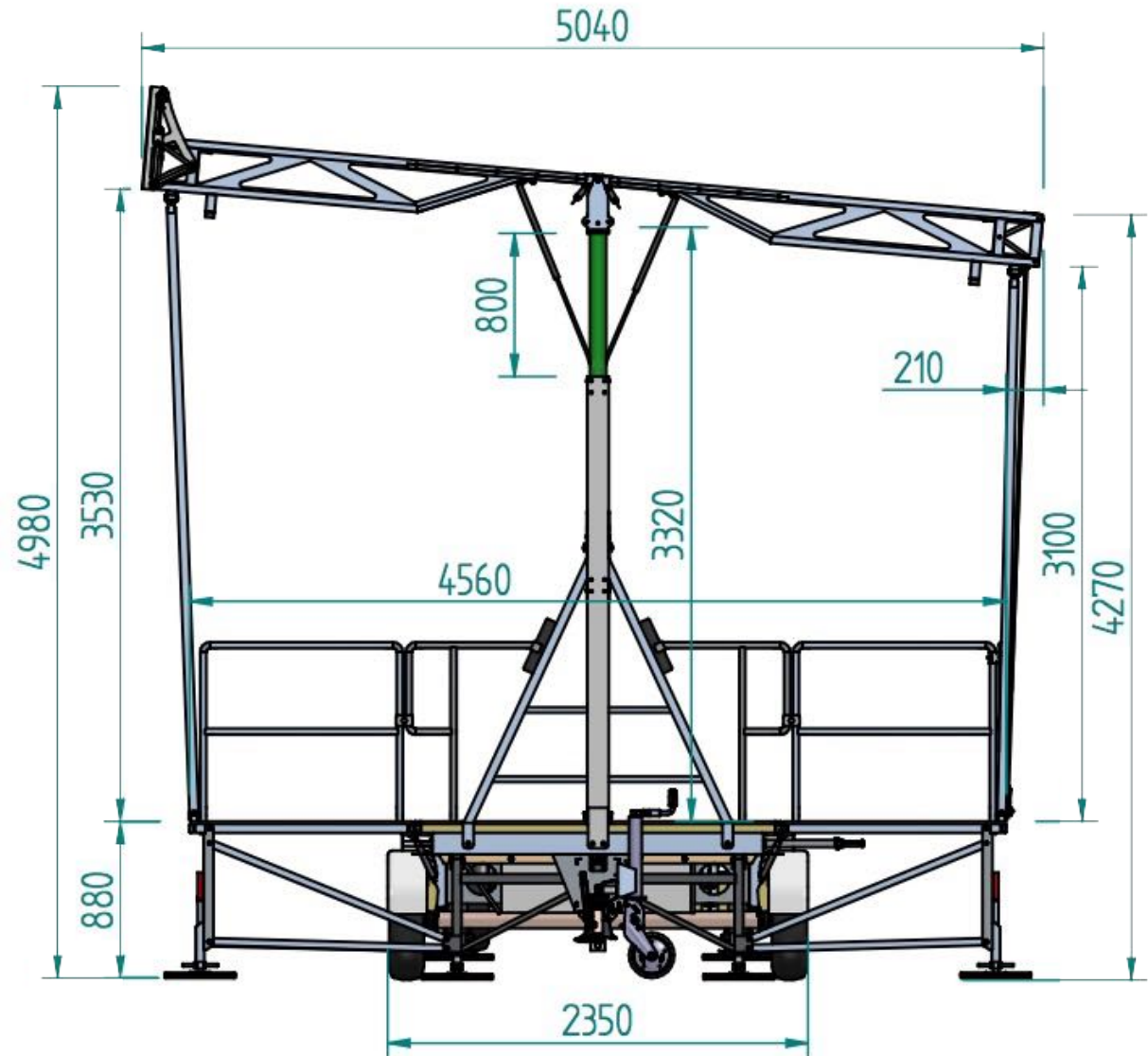

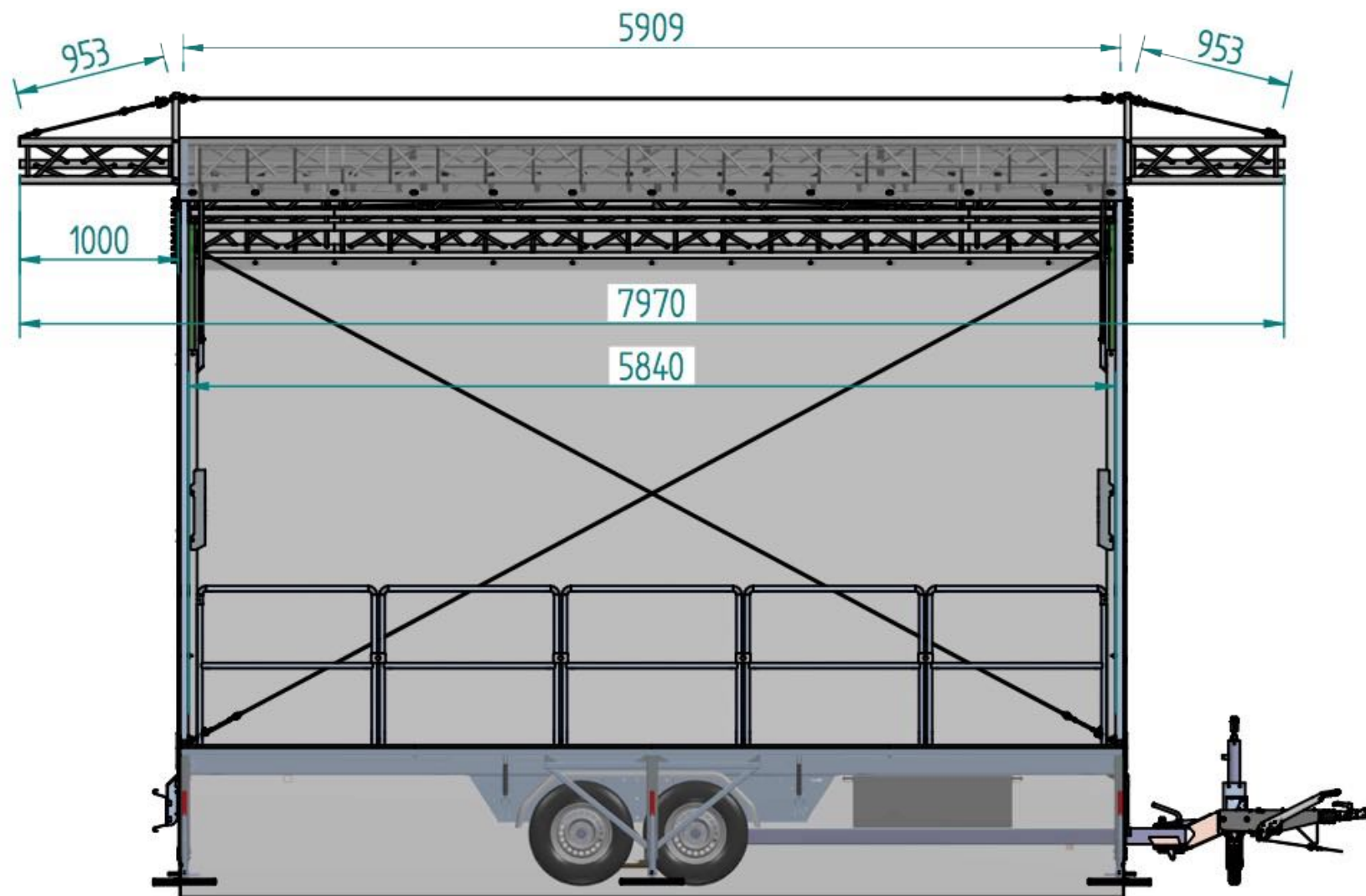

Plan SL90 – Ansicht

*Dachkonstruktion:*

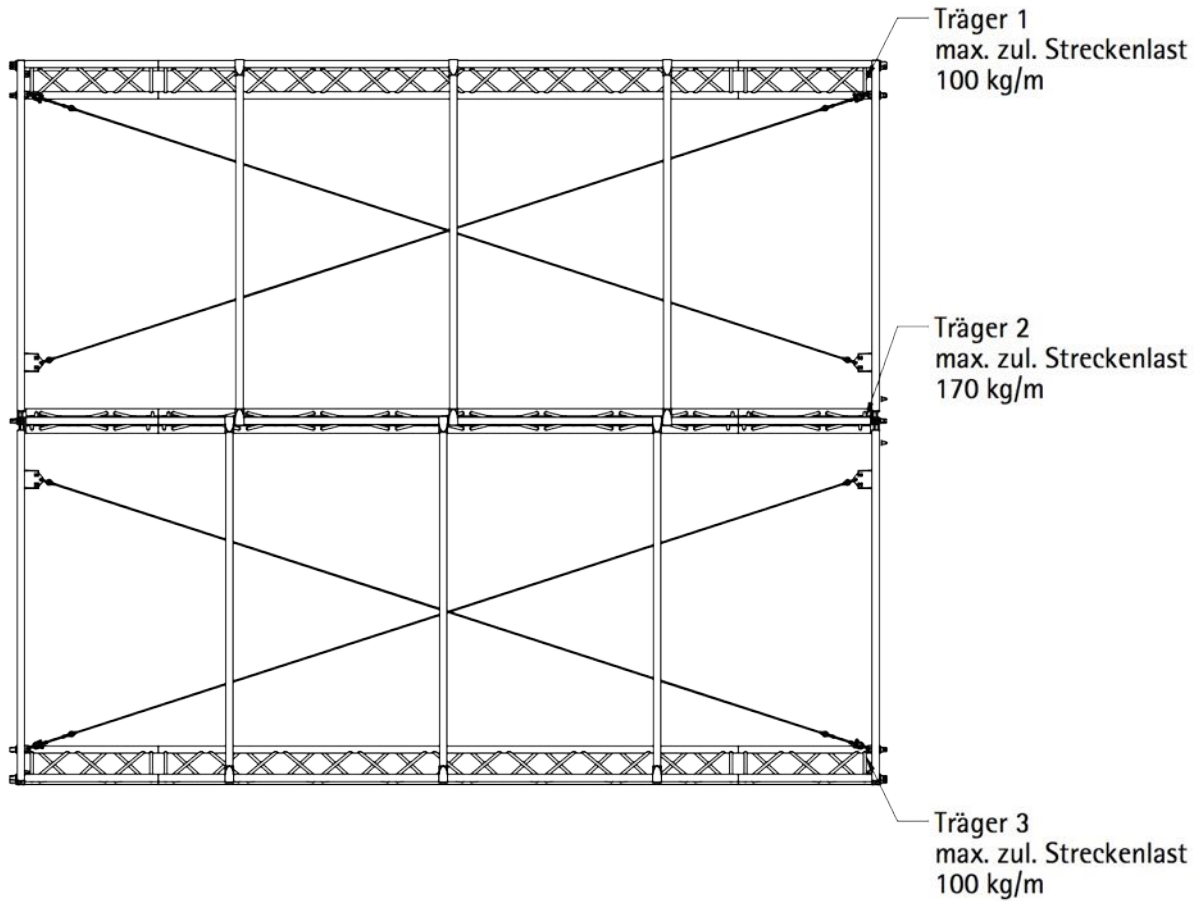

*Soundwing:*

